

WOLVERINE GRINDING JIG INSTRUCTIONS

CONTENTS OF PACKAGE

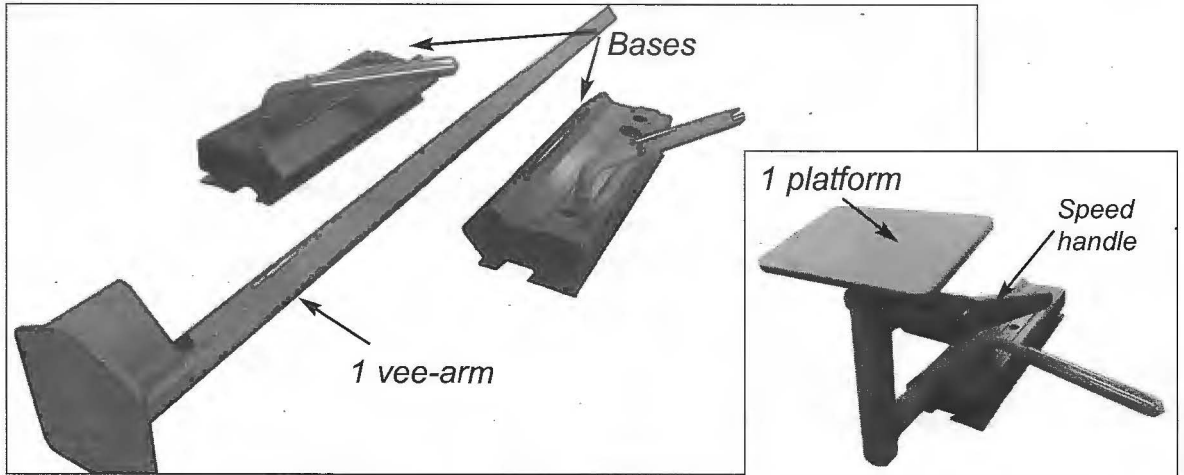

SETTING UP - MOUNTING THE BASES

For your new **ONEWAY** Wolverine Grinding Jig to work best, your grinder and your grinding jig should both be mounted on a board or a bench so that they cannot move in relation to each other. The base should be mounted directly centered under your grinding wheel. Slide the vee-arm into the base to ensure that the centre of the pocket lines up with the centre of your wheel.

The front of the base should be flush to the front of the grinding wheel. The base must be approximately 1/2" (or less) from the front of the mounting board. Once you have the base positioned use three screws to anchor it in place. Use the two end and one middle hole. These holes are countersunk for standard wood screws.

Two bases are provided for mounting one on each side of your grinder.

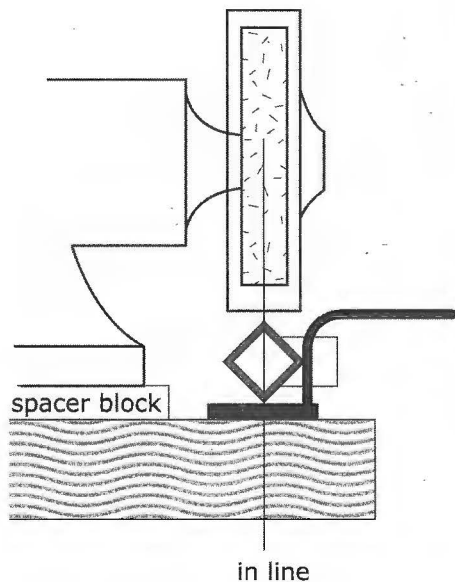
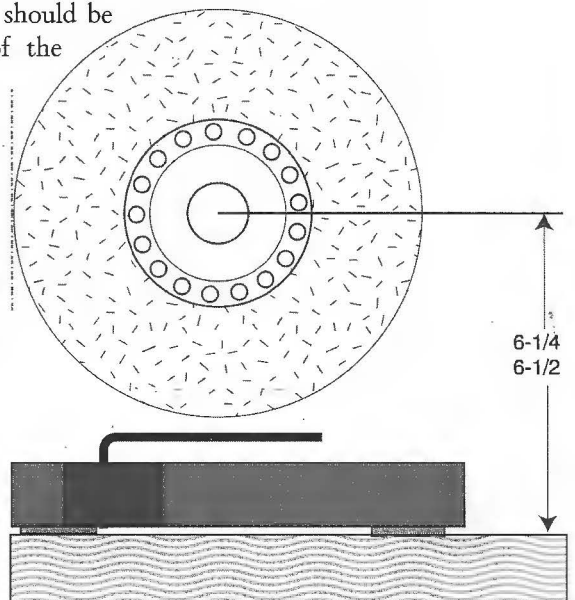

NOTES

1. Rubber feet underneath the grinder should be removed and be reinstalled underneath the mounting board if required.
2. With some grinders (particularly 6 inch grinders) it may be necessary to mount your grinder on a spacer approximately one inch thick to achieve the 6-1/4 minimum dimension. This will be necessary if any part of the base interferes with the wheel guards and when using the **ONEWAY** Dressing Jig.

INSTRUCTIONS FOR GRINDING

You now have two ways of supporting your tools for grinding:

1. the vee-arm and
2. the platform.

USING THE VEE-ARM

The vee-arm can be used to grind bowl-gouges, roughing gouges, and skewers.

All *Gouges* are ground with basically the same technique. Slide the vee-arm into the base. With the grinder turned off, rest the handle of your tool in the vee-arm pocket. Slide the vee-arm in or out of the base until the bevel of your gouge lays flat on your wheel and then

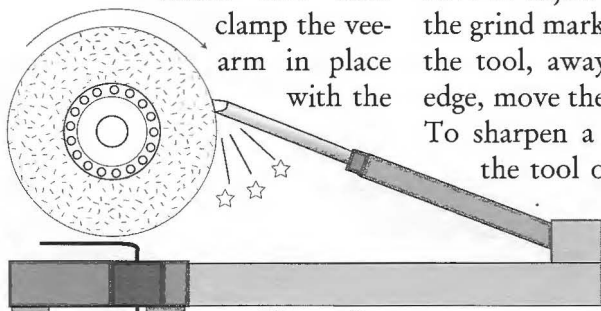
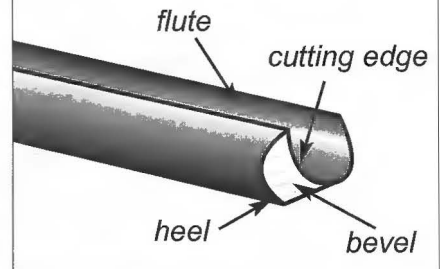

Figure 2

locking lever. Lift your gouge off the wheel and turn the grinder on. Gently touch your gouge to the wheel. Check the position of the vee-arm by lifting the tool off the wheel and looking at the grind marks on the bevel. If the grind marks are even on the whole bevel, then the vee arm is adjusted properly. If the grind marks are just on the cutting edge you will have to adjust the vee-arm in. If the grind marks are on the heel of the tool, away from the cutting edge, move the vee-arm out.

To sharpen a bowl gouge touch the tool on the wheel (fig 2) and roll the gouge to each corner of

TOOL NOMENCLATURE



the gouge. The further you roll the tool, the further back the ears will be ground. How far back you grind the corners is a matter of personal preference but most turners will grind them back about 10 to 20 degrees. A good general purpose bevel angle is 45 degrees (figure 3).

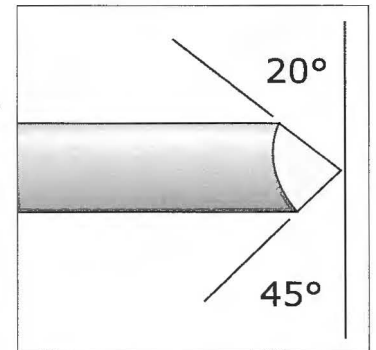

Figure 3: Bowl gouge side view

SHARPENING CHISELS

Standard wood chisels are easily ground using the base and vee-arm.

Adjust the arm to set the bevel and grind the chisel with small sideways motions and light cutting pressure.

Cool often as most chisels are carbon steel which softens when turned blue with heat. Three or four strokes on a strop will generate a razor sharp edge on this tool.

The roughing gouge is ground much the same way as a bowl-gouge but should have a different geometry when you are finished grinding. Instead of grinding the ears back 20 degrees, the end of the tool should remain square (figure 4).

When you are grinding these two tools you will find that different areas of the tool will grind away at different speeds. It is important to watch the shape of the tool as you are sharpening and to spend more time grinding some areas of the tool and less time grinding others. Also please note that bevel angles are starting values only. Modify them to meet your own turning style.



Figure 4: Roughing Gouge Side View

Skews are ground much the same as bowl or spindle gouges. Start by locating the bevel. After this step, a simple small sideways sliding motion will quickly regenerate a sharp tool. Use light cutting pressure, turn over frequently for even sharpening and keep the tool cool by dipping in water. After grinding, a few strokes on a strop will remove the small burrs present at the cutting edge. The skew and scraper are the only turning tools requiring stropping or honing of the cutting edge after grinding.

To sharpen the rounded skew or Richard Raffan shape, first establish your radius by grinding on the platform. Then grind in the vee-arm by rocking/rolling the tool exactly as when sharpening a gouge. A radius fixture is not needed to obtain this grind (figure 6).

End view of cutting edge of radius skew



Radius Skew Top View

Arrow shows motion skew must make on grinding wheel to grind this profile



Figure 6.

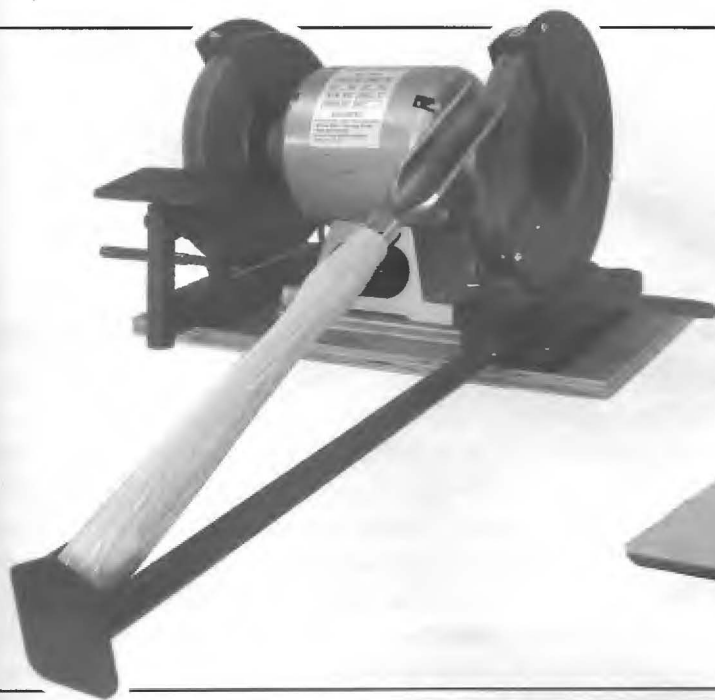

TIP

If you are **working on something** that will require the tool to be **resharpened** a number of times, leave the **vee-arm** clamped in place. This will allow you to quickly and easily reproduce the **bevel angle** and to remove minimal material from your tools. If a tool is dull when you are finished with it **resharpen** it before you put it away. That way all your tools are sharp all the time.



USING THE PLATFORM

With the grinder turned off, slide the assembled platform into the base. Please note that the platform can be used on the left or right side of the grinder. Clamp the platform arm in place with the locking lever so that the platform is held securely. Adjust the platform so that the tool meets the wheel at the desired angle. Reset to the minimum distance from the wheel before starting the grinder and proceeding to sharpen your tool.

SAFETY GUARD - Installation Instructions

1. Observe carefully the photos to the right.
2. Join the two sets of bend plates with the screws provided (as shown in Fig 1.) - ensure to adjust as far forward as possible. Note there is a left and right assembly (right is shown).
3. Now screw down the assembly to the grinder mounting board (as shown in Fig 2.).
4. Make any final adjustments to ensure the guard is within 1/8" of the wheel and secure. If possible, allow the guard to rest gently on the grinder guard for extra support.

The guard will fit most grinders.

FIG. 1



FIG. 2



AVAILABLE ACCESSORIES & ATTACHMENTS



VARI-GRIND ATTACHMENT

Do you find it impossible to reproduce the grind on your bowl gouge without grinding half your tool away?

The Vari-Grind Attachment will consistently produce sharp, repeatable geometries on turning tools. Three tools that are very popular and useful are the classic fingernail shape, the traditional bowl gouge and the new side grind configurations. These shapes however are difficult both to grind and to maintain. The Vari-Grind Attachment will easily and consistently

perform the following:

- ✓ fingernail grind
- ✓ bowl gouge grind
- ✓ side or Irish grind

Vari-Grind Part No. 2480

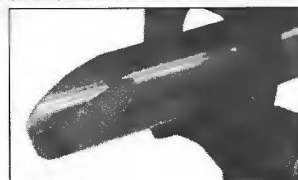

Side Grind (Irish Grind)

While attending many wood shows and symposiums, designers at **ONEWAY** recognized that the side (or long grind) on deep fluted bowl gouges has become very popular. This shape is superb for rapid hollowing, and is useful on the outside of bowls. Once you learn how to use it, it will be one of your favorite grinds.

VARI-GRIND 2 ATTACHMENT

Vari-Grind 2 - Part No. 3900



Similar to the above ONEWAY Vari-Grind is the new Vari-Grind 2. The Vari-Grind 2 keeps all the flexibility of the Original Vari-Grind but adds safety and increases the ease of use. The new Vari-Grind 2 restrains tool motion in two directions. The side to side motion of the tool is restrained, so that the tool cannot slip off the side of the wheel. The pivot point on the new Vari-Grind 2 is also restrained. These changes increase safety and reduce the possibility of mistakes while sharpening. The truly exciting feature of the new Vari-Grind 2 is the patented pivot point location. The cutting edge of the tool moves in a true cylindrical motion about the adjusting rod. This is a totally unique feature and is patent applied for. The pivot point location is a great feature in that both a true fingernail and a true side grind can be ground with the jig at any bevel angle. The ONEWAY Vari-Grind 2 is the only restrained grinding jig that has this function.

SKEW JIG

Save TIME and MONEY with Oneway's Skew Grind, every time you use it!

Our Skew Jig (specifically designed to work with our Wolverine Grinding Jig) will achieve the following:

- ✓ sharpening with increased safety
- ✓ effortless flat bevels
- ✓ bevel and cutting edge parallel
- ✓ sharpening the same bevel every time with
- ✓ minimal material waste

One reason that the skew leaves such an incredible finish on work pieces is due to its very thin edge which leaves naturally cleaner cuts. This creates a problem with sharpening the skew as this thin edge will easily fold over during grinding. **ONEWAY's** Skew Grinding Attachment minimizes this problem by allowing the skew to be mechanically held. The unique offset handle position

actually reduces the hollow grind generated and leaves a stronger more predictable tool.

This fixture is a highly recommended option with our Wolverine Grinding System.



Skew Grind Attachment Part No. 2690

WHEEL DRESSING - WOLVERINE DRESSING ATTACHMENT

Grinding wheels must be dressed to keep them sharp and clean. Grinding wheels, like sandpaper, become dull with use; the grit breaks down and becomes dull. If grinding wheels are not sharp, they begin rubbing rather than cutting, which results in increased friction. Higher temperatures and burned tools are the result. Wheels must also be kept free from metal particles that build up during sharpening. Like sandpaper that gets clogged with sawdust during sanding, grinding wheels become clogged with metal particles during grinding.

For optimum result when grinding tools, we suggest you obtain our Wolverine Dressing Attachment. It is the only dresser available for low cost bench grinders allowing controlled removal of the 0.001" to 0.002" per pass required. We guarantee a round, clean, sharp wheel when using this dresser on balanced wheels.



Wolverine Dressing Attachment Part No. 2292

WHEEL BALANCING

Sharpening tools can be difficult for many reasons. One problem can occur because grinding wheels are sensitive to vibration due to their mass and speed. Often vibrations are responsible for inferior finishes on the tools that are being ground. They can also

harm the bearings and bearing housings of the machine. Most vibrations are caused by unbalanced grinding wheels. Unfortunately bench or pedestal grinders do not come equipped with a means to balance wheels.

ONEWAY's Balancing system compensates for: out of round wheels, wheel density, and thickness side to side variation of the wheel.

With balanced wheels you will get better grinding performance. Once completed, rebalancing should not be necessary for the life of the wheels. You will get better performance needed to get sharp tools for better finishes on your turning projects.

1/2" Balance Kit Part No. 2524

5/8" Balance Kit Part No. 2272

3/4" Balance Kit Part No. 2535

NOTES: Baldor grinders require special washers. The Delta variable speed grinder requires regular 5/8 washers.

GRINDING WHEELS

Grinding wheels are an integral part of the grinding process. The wheels ONEWAY offers have been manufactured to our specifications after considerable testing and in conjunction with our manufacturers advice and expertise.

For grinding carbon, and particularly high speed steel, select a ONEWAY grinding wheel suitable for your grinder size and consider the following suggestions:

- If your grind mostly large tools with a large contact area on the grinder, such as skews, flat scrapers and carpenter chisels, choose 54 grit for roughing and 80 grit for finishing.
- For grinding small tools, and for finishing large gouges, choose 80 and 120 grit wheels.

If your grinding wheel glazes over quickly and wears away from sharpening, while throwing off grinding dust, consider purchasing a different grinding wheel.

ONEWAY's grinding wheels are specially manufactured to grind high speed steel on bench grinders.



AVAILABLE ACCESSORIES & ATTACHMENTS

WOLVERINE GRIND 'N HONE

At last... a Honing Jig that goes directly from the Grinder to the honing stone in one setting!

This clever new jig will sharpen chisels and plane irons up to two and a half inches wide on any 6" to 8" bench or pedestal grinder. Good visual control prevents overheating while the rigid clamping mechanism and smooth glide bearings makes honing a breeze. Sharpening using this jig is extremely fast and easily repeatable.

What setup is required?

Setup is fast and easy. In as little as a few minutes you can be restoring those old plane irons and chisels to an amazing sharpness.

What grinder setup do I need?

The Jig can be used on any bench or pedestal grinder (6", 7" or 8").

What about honing stones?

You can use any stones to hone on. We recommend good quality stones in order to get the best possible finish on your tools.

Can be purchased as an accessory to the WOLVERINE GRINDING JIG or as a Complete System. The only difference between these two options is that the Complete System includes a Base, whereas the accessory to the Wolverine Grinding Jig does not (as you already have two bases).

Grind 'n Hone Accessory Kit

Part No. 3865

Grind 'n Hone Complete Pkg

Part No. 3859



MINI PLATFORM ASSEMBLY



The Mini Platform Assembly is similar to the platform included in the Grinding Jig set, however it has a smaller surface area, with a curved edge on the turner's end of the platform to allow closer access to the grinding wheel at more angles for your smallest of tools. The Mini Platform Assembly has the same working features as its full sized counterpart; the same speed handle for tightening the platform, the same mounting arm that slides into the base of the Grinding Jig, and the same quality material and manufacturing that you expect from ONEWAY products. This platform is helpful for the woodturner who requires precision sharpening for their 1/8" and 1/4" tools.

Mini Platform Assembly Part No. 3945

Manufacturers Warranty

Date Purchased:

This Oneway product is backed by a warranty period of **5 years** from the date of purchase.

Oneway hereby agrees to repair or replace any defects due to faulty material or workmanship, provided that:

1. The warranty period has not elapsed. Proof of purchase date (sales receipt etc.) is required prior to any repair taking place.
2. The product has not been altered or modified in any way.
3. The product has not been subjected to misuse, abuse, negligence, or was not used strictly in accordance with these instructions.
4. Transportation costs incurred in returning the product to Oneway is pre-paid by the customer.

This warranty does not cover any costs or damages arising directly or indirectly from the operation of this product.

No other guarantee, written or verbal, is authorized by Oneway Manufacturing.

Our policy is one of continuous improvement. We therefore reserve the right to change the specification and/or design without notice.